

C.I.P.

284 Win.

Country of Origin: US

TAB. I

Date 84-06-14

Revision 02-05-15

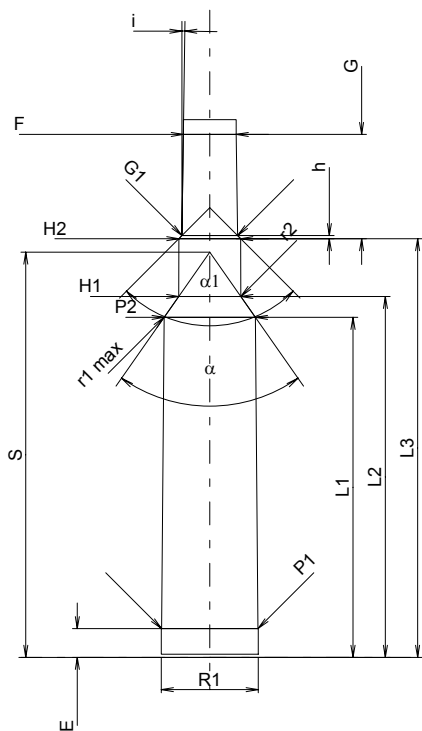
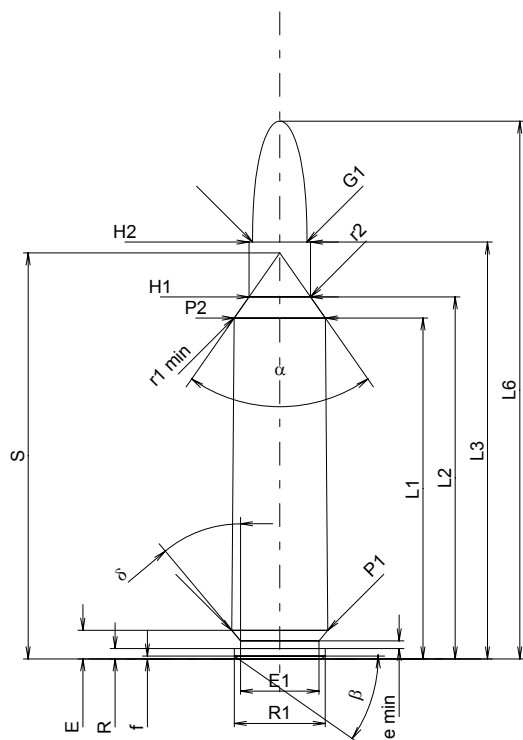

Scale 1:1

Dimensions in << mm >>
Dimensions and Tolerances for Proof Barrels
see Appendix CR 1.

CARTRIDGE MAXI

Lengths

L1 ¹⁾	=	45.08	-0.20
L2 ¹⁾	=	47.88	-0.20
L3 ¹⁾	=	55.12	
L4	=		
L5	=		
L6	=	71.12	

Case Head

R	=	1.37	
R1	=	12.01	
R3	=		
E	=	3.78	
E1	=	10.39	
e min	=	1.02	
delta	=	40°	
f	=	0.38	
beta	=	35°	

Powder Chamber

P1	=	12.72	
P2 ^{1)*}	=	12.06	-0.20

Junction Cone

alpha*	=	70°	
S*	=	53.69	
r1 min	=	0.76	
r2	=	3.18	

Collar

H1*	=	8.13	
H2 ¹⁾	=	8.13	

Projectile

G1 ¹⁾	=	7.21	
G2	=		
F	=		
L3+G ¹⁾	=	68.90	

Pressures (Energies)

Method Transducer

Pmax	=	4400 bar	
PK	=	5060 bar	
PE	=	5500 bar	
M	=	25.00	
EE	=	3625 Joule	

Miscellaneous Dimensions

Fe ¹⁾	=	0.10	
delta L	=	0.09	

CHAMBER MINI

Lengths

L1	=	44.96	
L2	=	47.73	
L3 ¹⁾	=	55.37	

Breech

R	=		
R1	=	12.81	
R2	=		
R3	=		
r	=		

Powder Chamber

E	=	3.78	
P1 ¹⁾	=	12.75	
P2*	=	12.09	

Junction Cone

alpha ^{1)*}	=	70°	
S*	=	53.59	
r1 max	=	0.76	
r2	=	3.18	

Collar

H1*	=	8.20	
H2 ¹⁾	=	8.18	

Commencement of Rifling

G1 ^{1)*}	=	7.37	
G ¹⁾	=	13.78	
alpha1*	=	90°	
h	=	0.41	
s	=		
i ^{1)*}	=	1°47'33"	
w	=		

Barrel

F ^{1)*}	=	7.00	
Z ¹⁾	=	7.19	

Grooves

b	=	2.79	
N	=	6	
u	=	254.00	
Q	=	40.12	mm ²

Notes: 1) Check for safety reasons
* Basic dimensions